

801-176 10' SINGLE ENTRY BIKE RACK

IMPORTANT

PLEASE READ THESE INSTRUCTIONS BEFORE COMMENCING ASSEMBLY. All equipment must be installed in accordance with these instructions. Check your shipment against Bill of Lading and Parts list. Any missing or broken parts must be reported to your distributor within 10 days of receipt of your order. When properly installed and maintained, equipment will give many years of Safe, Trouble-Free use. Periodically check for loose or broken parts. Loose bolts must be tightened and broken parts must be replaced as they can possibly create dangerous situations leading to unnecessary accidents. Resilient Surfacing should be used under all playground equipment. Appropriate publications, available at no charge, from the Consumer Product Safety Commission, include "A Handbook for Public Playground Safety". You can receive your free copy by calling 1-301-504-7908.

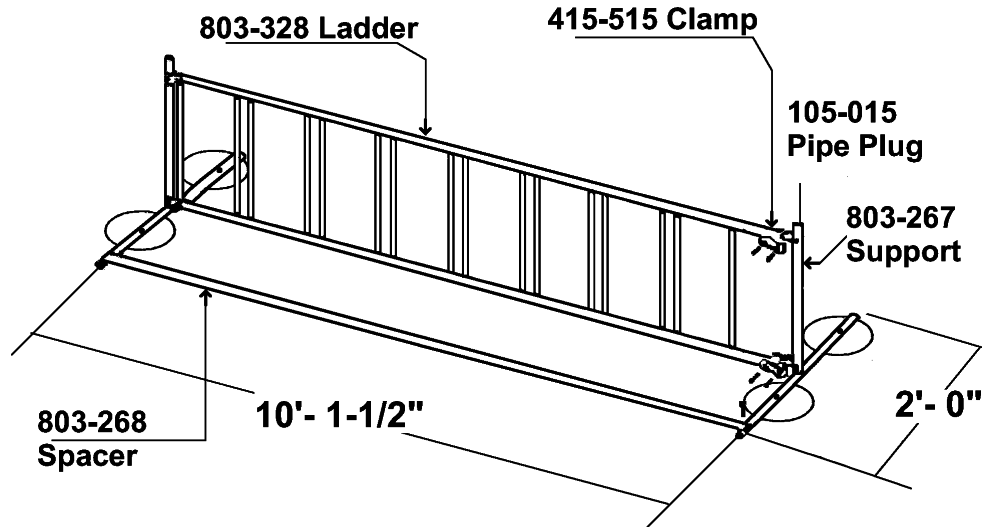

Main Frame, legs and spacers are 1 5/8" O.D. hot galvanized welded pipe with 3/4" O.D. hot galvanized ladder rungs. Spacing between tire posts is 3" center-to-center for small gap, 8 1/2" center-to-center for large gap.

PACKING LIST

1	CTN		Hardware Bag
1	PIPE	1 803-268	Spacer Bar
1	BDL	2 803-267	End Support
1	WF	1 803-326	Ladder

HARDWARE BAG

2	116-514	5/16" x 3 1/2" Hex Bolt
8	116-510	5/16" x 2 1/2" Hex Bolt
10	326-501	5/16" Lock Washer
4	216-601	3/8" Hex Nut
4	226-601	3/8" Lock Nut
10	226-501	5/16" Lock Nut
4 pr	415-515	1 5/8" T-Clamp
8	105-015	1 5/8" Pipe Plug
4	196-644	3/8" x 8" Anchor Bolt

1 CTN	1 BDL	1 WF	1 PIPE	4 TOT PCS.	Weight 100#	CLASS 70
-------	-------	------	--------	------------	-------------	----------

801-176 10' SINGLE ENTRY BIKE RACK

GENERAL ASSEMBLY INSTRUCTIONS:

Check all the parts and hardware with the packing list to be sure you have received everything needed to assemble this product. CONTACT YOUR LOCAL DISTRIBUTOR WITH NOTIFICATION OF ANY MISSING OR DAMAGED PARTS. Contact must be made within ten days of receipt of your order.

Only hand-tighten nuts & bolts on initial assembly. Final tightening should be done **EVENLY** after final assembly when unit has been plumbed & leveled.

After assembly is complete, **ANY ENDS OF BOLTS PROTRUDING BEYOND NUTS SHOULD BE CUT OFF AND/OR PEENED OVER TO REMOVED ANY SHARP PROJECTIONS.** Go over entire unit to file smooth any sharp edges or projections that may have been caused by rough handling in shipping or installation. T-Clamps are designed for both one and two bolt connections. In many situations only one bolt is required. See specific assembly instructions.

On products with platforms install 1-2 degrees off level to facilitate water drainage.

USE AREA AND FOOTING LAYOUT

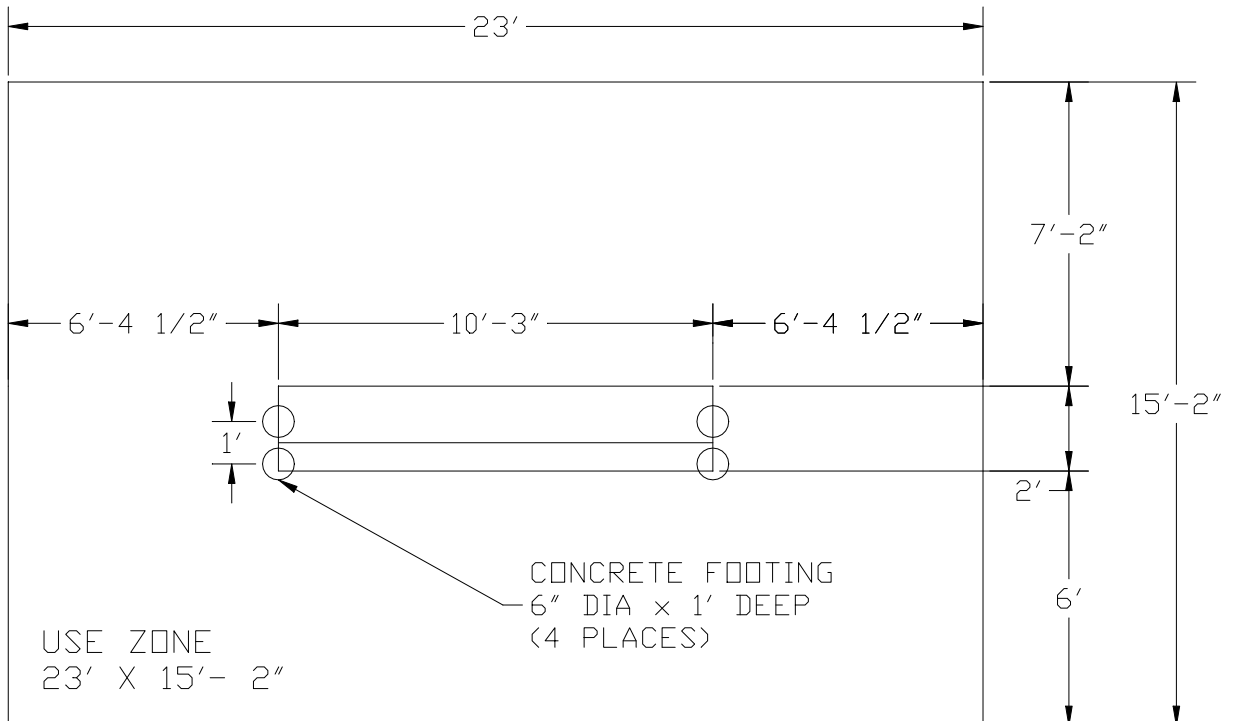

801-176 10' SINGLE ENTRY BIKE RACK

GENERAL MAINTENANCE INSTRUCTIONS:

Check MONTHLY for loose bolts, damaged or broken parts. Tighten and/or replace immediately.

SPECIFIC ASSEMBLY INSTRUCTIONS:

- STEP #1: Completely assemble Bike Rack.
STEP #2: Position Bike Rack in proper position, mark footing holes, move Bike Rack to one side, and dig holes.
STEP #3: Assemble Anchor Bolts to end supports and place Bike Rack in position over footing holes.
STEP #4: Pour concrete. Crown surface, plumb and level. Wait 48 hours before using equipment.

T-Clamp Detail:

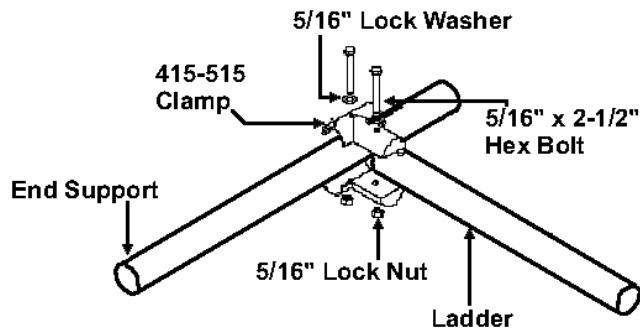

End Support and Spacer Detail:

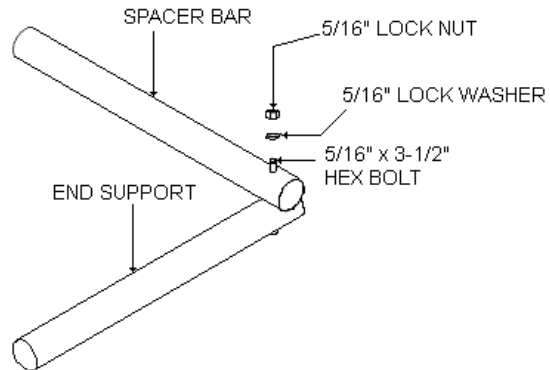

Anchor Bolt Detail:

